

100351 Low Power Hex D-Type Flip-Flop

General Description

The 100351 contains six D-type edge-triggered, master/slave flip-flops with true and complement outputs, a pair of common Clock inputs (CP_a and CP_b) and common Master Reset (MR) input. Data enters a master when both CP_a and CP_b are LOW and transfers to the slave when CP_a and CP_b (or both) go HIGH. The MR input overrides all other inputs and makes the Q outputs LOW. All inputs have 50 kΩ pull-down resistors.

Features

- 40% power reduction of the 100151
- 2000V ESD protection
- Pin/function compatible with 100151
- Voltage compensated operating range:
-4.2V to -5.7V
- Available to industrial grade temperature range

Ordering Code:

Order Number	Package Number	Package Description
100351SC	M24B	24-Lead Small Outline Integrated Circuit (SOIC), JEDEC MS-013, 0.300 Wide
100351PC	N24E	24-Lead Plastic Dual-In-Line Package (PDIP), JEDEC MS-010, 0.400 Wide
100351QC	V28A	28-Lead Plastic Lead Chip Carrier (PLCC), JEDEC MO-047, 0.450 Square
100351QI	V28A	28-Lead Plastic Lead Chip Carrier (PLCC), JEDEC MO-047, 0.450 Square Industrial Temperature Range (-40°C to +85°C)

Devices also available in Tape and Reel. Specify by appending the suffix letter "X" to the ordering code.

Logic Symbol

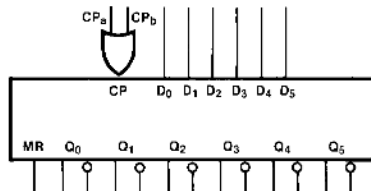

Connection Diagrams

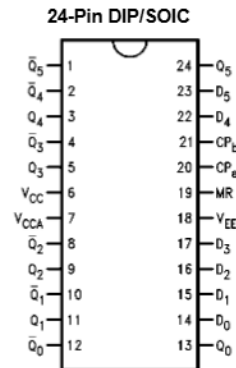

Pin Descriptions

Pin Names	Description
D ₀ -D ₅	Data Inputs
CP _a , CP _b	Common Clock Inputs
MR	Asynchronous Master Reset Input
Q ₀ -Q ₅	Data Outputs
Q̄ ₀ -Q̄ ₅	Complementary Data Outputs

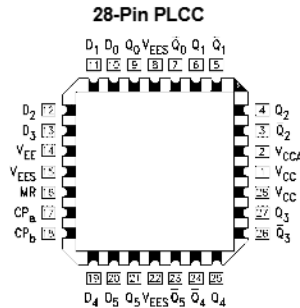

Truth Tables

(Each Flip-flop)

Synchronous Operation

Inputs				Outputs
D _n	CP _a	CP _b	MR	Q _n (t+1)
L	↗	L	L	L
H	↗	L	L	H
L	L	↗	L	L
H	L	↗	L	H
X	H	↗	L	Q _n (t)
X	↗	H	L	Q _n (t)
X	L	L	L	Q _n (t)

Asynchronous Operation

Inputs				Outputs
D _n	CP _a	CP _b	MR	Q _n (t+1)
X	X	X	H	L

H = HIGH Voltage Level

L = LOW Voltage Level

X = Don't Care

t = Time before CP positive transition

t+1 = Time after CP positive transition

↗ = LOW-to-HIGH transition

Logic Diagram

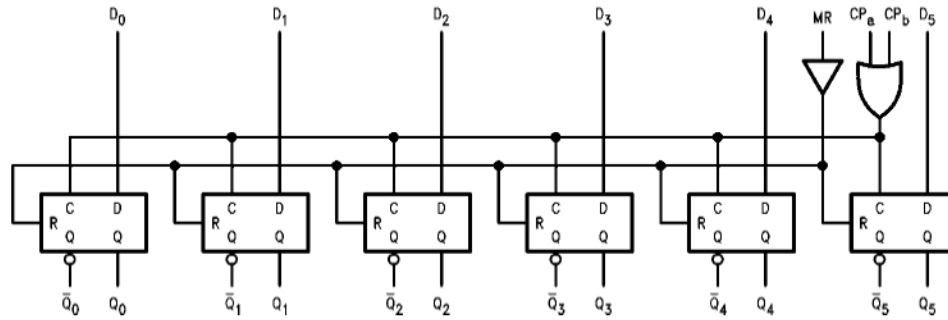

Absolute Maximum Ratings(Note 1)

Storage Temperature (T_{STG})	-65°C to +150°C
Maximum Junction Temperature (T_J)	+150°C
V_{EE} Pin Potential to Ground Pin	-7.0V to +0.5V
Input Voltage (DC)	V_{EE} to +0.5V
Output Current (DC Output HIGH)	-50 mA
ESD (Note 2)	≥2000V

Recommended Operating Conditions

Case Temperature (T_C)	Commercial	0°C to +85°C
	Industrial	-40°C to +85°C
Supply Voltage (V_{EE})		-5.7V to -4.2V

Note 1: The "Absolute Maximum Ratings" are those values beyond which the safety of the device cannot be guaranteed. The device should not be operated at these limits. The parametric values defined in the Electrical Characteristics tables are not guaranteed at the absolute maximum rating. The "Recommended Operating Conditions" table will define the conditions for actual device operation.

Note 2: ESD testing conforms to MIL-STD-883, Method 3015.

Commercial Version**DC Electrical Characteristics** (Note 3)

$V_{EE} = -4.2V$ to $-5.7V$, $V_{CC} = V_{CCA} = GND$, $T_C = 0^\circ C$ to $+85^\circ C$

Symbol	Parameter	Min	Typ	Max	Units	Conditions
V_{OH}	Output HIGH Voltage	-1025	-955	-870	mV	$V_{IN} = V_{IH}$ (Max) or V_{IL} (Min) Loading with 50Ω to -2.0V
V_{OL}	Output LOW Voltage	-1830	-1705	-1620		
V_{OHC}	Output HIGH Voltage	-1035			mV	$V_{IN} = V_{IH}$ (Min) or V_{IL} (Max) Loading with 50Ω to -2.0V
V_{OLC}	Output LOW Voltage			-1610		
V_{IH}	Input HIGH Voltage	-1165		-870	mV	Guaranteed HIGH Signal for All Inputs
V_{IL}	Input LOW Voltage	-1830		-1475	mV	Guaranteed LOW Signal for All Inputs
I_{IL}	Input LOW Current	0.50			μA	$V_{IN} = V_{IL}$ (Min)
I_{IH}	Input HIGH Current			350	μA	$V_{IN} = V_{IH}$ (Max)
	MR			240		
	D_0 - D_5 CP_a , CP_b			350		
I_{EE}	Power Supply Current	-129		-62	mA	Inputs OPEN

Note 3: The specified limits represent the "worst case" value for the parameter. Since these values normally occur at the temperature extremes, additional noise immunity and guardbanding can be achieved by decreasing the allowable system operating ranges. Conditions for testing shown in the tables are chosen to guarantee operation under "worst case" conditions.

DIP AC Electrical Characteristics

$V_{EE} = -4.2V$ to $-5.7V$, $V_{CC} = V_{CCA} = GND$

Symbol	Parameter	$T_C = 0^\circ C$		$T_C = +25^\circ C$		$T_C = +85^\circ C$		Units	Conditions
		Min	Max	Min	Max	Min	Max		
f_{MAX}	Toggle Frequency	375		375		375		MHz	Figures 2, 3
t_{PLH}	Propagation Delay	0.80	2.00	0.80	2.0	0.90	2.10	ns	Figures 1, 3
t_{PHL}	CP _a , CP _b to Output								
t_{PLH}	Propagation Delay	1.10	2.30	1.10	2.30	1.20	2.40	ns	Figures 1, 4
t_{PHL}	MR to Output								
t_{TLH}	Transition Time	0.35	1.20	0.35	1.20	0.35	1.20	ns	Figures 1, 3
t_{THL}	20% to 80%, 80% to 20%								
t_S	Setup Time								
	D_0 - D_5	0.40		0.40		0.40		ns	Figure 5
	MR (Release Time)	1.60		1.60		1.60		ns	Figure 4
t_H	Hold Time	0.80		0.80		0.80		ns	Figure 5
	D_0 - D_5								
$t_{PW(H)}$	Pulse Width HIGH	2.00		2.00		2.00		ns	Figures 3, 4
	CP _a , CP _b , MR								

Commercial Version (Continued)
SOIC and PLCC AC Electrical Characteristics
 $V_{EE} = -4.2V$ to $-5.7V$, $V_{CC} = V_{CCA} = GND$

Symbol	Parameter	$T_C = 0^\circ C$		$T_C = +25^\circ C$		$T_C = +85^\circ C$		Units	Conditions
		Min	Max	Min	Max	Min	Max		
f_{MAX}	Toggle Frequency	375		375		375		MHz	Figures 2, 3
t_{PLH} t_{PHL}	Propagation Delay CP _a , CP _b to Output	0.80	1.80	0.80	1.80	0.90	1.90	ns	Figures 1, 3
t_{PLH} t_{PHL}	Propagation Delay MR to Output	1.10	2.10	1.10	2.10	1.20	2.20	ns	Figures 1, 4
t_{TLH} t_{THL}	Transition Time 20% to 80%, 80% to 20%	0.45	1.70	0.45	1.60	0.45	1.70	ns	Figures 1, 3
t_S	Setup Time D ₀ -D ₅	0.30		0.30		0.30		ns	Figure 5
	MR (Release Time)	1.50		1.50		1.50		ns	Figure 4
t_H	Hold Time D ₀ -D ₅	0.80		0.80		0.80		ns	Figure 5
$t_{PW(H)}$	Pulse Width HIGH CP _a , CP _b , MR	2.00		2.00		2.00		ns	Figures 3, 4
t_{OSHL}	Maximum Skew Common Edge Output-to-Output Variation Clock to Output Path		220		220		220	ps	PLCC only (Note 4)
t_{OSLH}	Maximum Skew Common Edge Output-to-Output Variation Clock to Output Path		210		210		210	ps	PLCC only (Note 4)
t_{OST}	Maximum Skew Opposite Edge Output-to-Output Variation Clock to Output Path		240		240		240	ps	PLCC only (Note 4)
t_{PS}	Maximum Skew Pin (Signal) Transition Variation Clock to Output Path		230		230		230	ps	PLCC only (Note 4)

Note 4: Output-to-Output Skew is defined as the absolute value of the difference between the actual propagation delay for any outputs within the same packaged device. The specifications apply to any outputs switching in the same direction either HIGH-to-LOW (t_{OSHL}), or LOW-to-HIGH (t_{OSLH}), or in opposite directions both HL and LH (t_{OST}). Parameters t_{OST} and t_{PS} guaranteed by design.

Industrial Version

PLCC DC Electrical Characteristics

$V_{EE} = -4.2V$ to $-5.7V$, $V_{CC} = V_{CCA} = GND$, $T_C = 0^\circ C$ to $+85^\circ C$ (Note 5)

Symbol	Parameter	$T_C = -40^\circ C$		$T_C = 0^\circ$ to $+85^\circ C$		Units	Conditions
		Min	Max	Min	Max		
V_{OH}	Output HIGH Voltage	-1085	-870	-1025	-870	mV	$V_{IN} = V_{IH}$ (Max) or V_{IL} (Min)
V_{OL}	Output LOW Voltage	-1830	-1575	-1830	-1620		
V_{OHC}	Output HIGH Voltage	-1095		-1035		mV	$V_{IN} = V_{IH}$ (Min) or V_{IL} (Max)
V_{OLC}	Output LOW Voltage		-1565		-1610		
V_{IH}	Input HIGH Voltage	-1170	-870	-1165	-870	mV	Guaranteed HIGH Signal for All Inputs
V_{IL}	Input LOW Voltage	-1830	-1480	-1830	-1475		
I_{IL}	Input LOW Current	0.50		0.50		μA	$V_{IN} = V_{IL}$ (Min)
I_{IH}	Input HIGH Current		350		350	μA	$V_{IN} = V_{IH}$ (Max)
	MR		240		240		
	D_0-D_5 CP_a, CP_b		350		350		
I_{EE}	Power Supply Current	-129	-62	-129	-62	mA	Inputs OPEN

Note 5: The specified limits represent the "worst case" value for the parameter. Since these values normally occur at the temperature extremes, additional noise immunity and guardbanding can be achieved by decreasing the allowable system operating ranges. Conditions for testing shown in the tables are chosen to guarantee operation under "worst case" conditions.

PLCC AC Electrical Characteristics

$V_{EE} = -4.2V$ to $-5.7V$, $V_{CC} = V_{CCA} = GND$

Symbol	Parameter	$T_C = -40^\circ C$		$T_C = +25^\circ C$		$T_C = +85^\circ C$		Units	Conditions
		Min	Max	Min	Max	Min	Max		
f_{MAX}	Toggle Frequency	375		375		375		MHz	Figures 2, 3
t_{PLH} t_{PHL}	Propagation Delay CP_a, CP_b to Output	0.80	1.80	0.80	1.80	0.90	1.90	ns	Figures 1, 3
t_{PLH} t_{PHL}	Propagation Delay MR to Output	1.10	2.10	1.10	2.10	1.20	2.20	ns	Figures 1, 4
t_{TLH} t_{THL}	Transition Time 20% to 80%, 80% to 20%	0.45	1.70	0.45	1.60	0.45	1.70	ns	Figures 1, 3
t_S	Setup Time D_0-D_5 MR (Release Time)	0.60		0.30		0.30		ns	Figure 5 Figure 4
t_H	Hold Time D_0-D_5	0.60		0.90		0.90			
$t_{PW(H)}$	Pulse Width HIGH CP_a, CP_b, MR	2.00		2.00		2.00		ns	Figures 3, 4

Test Circuitry

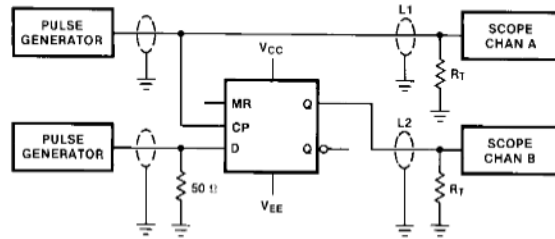

Notes:

$V_{CC}, V_{CCA} = +2V, V_{EE} = -2.5V$

L1 and L2 = equal length 50Ω impedance lines

$R_T = 50\Omega$ terminator internal to scope

Decoupling 0.1 μF from GND to V_{CC} and V_{EE}

All unused outputs are loaded with 50Ω to GND

C_L = Fixture and stray capacitance ≤ 3 pF

FIGURE 1. AC Test Circuit

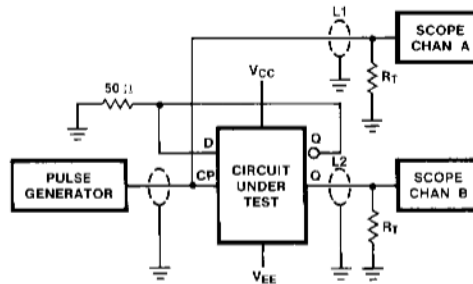

Notes:

$V_{CC}, V_{CCA} = +2V, V_{EE} = -2.5V$

L1 and L2 = equal length 50Ω impedance lines

$R_T = 50\Omega$ terminator internal to scope

Decoupling 0.1 μF from GND to V_{CC} and V_{EE}

All unused outputs are loaded with 50Ω to GND

C_L = Jig and stray capacitance ≤ 3 pF

FIGURE 2. Toggle Frequency Test Circuit

Switching Waveforms

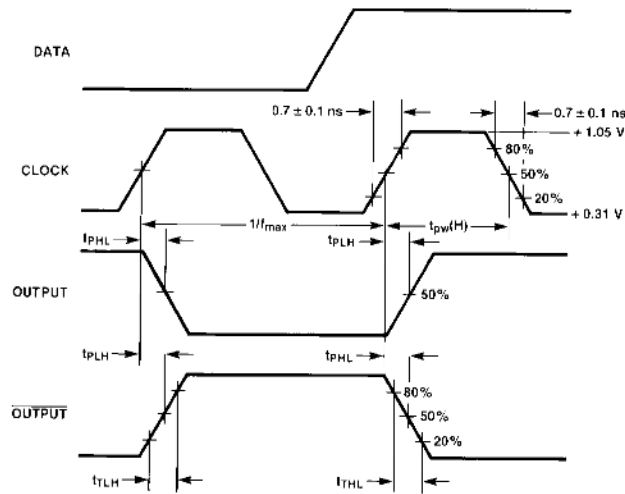

FIGURE 3. Propagation Delay (Clock) and Transition Times

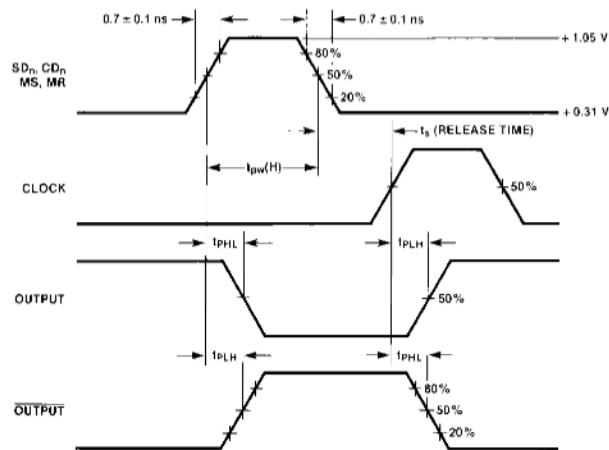
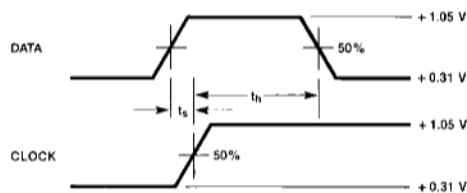

FIGURE 4. Propagation Delay (Reset)



Notes:

t_s is the minimum time before the transition of the clock that information must be present at the data input.

t_h is the minimum time after the transition of the clock that information must remain unchanged at the data input.

FIGURE 5. Setup and Hold Time

Physical Dimensions inches (millimeters) unless otherwise noted

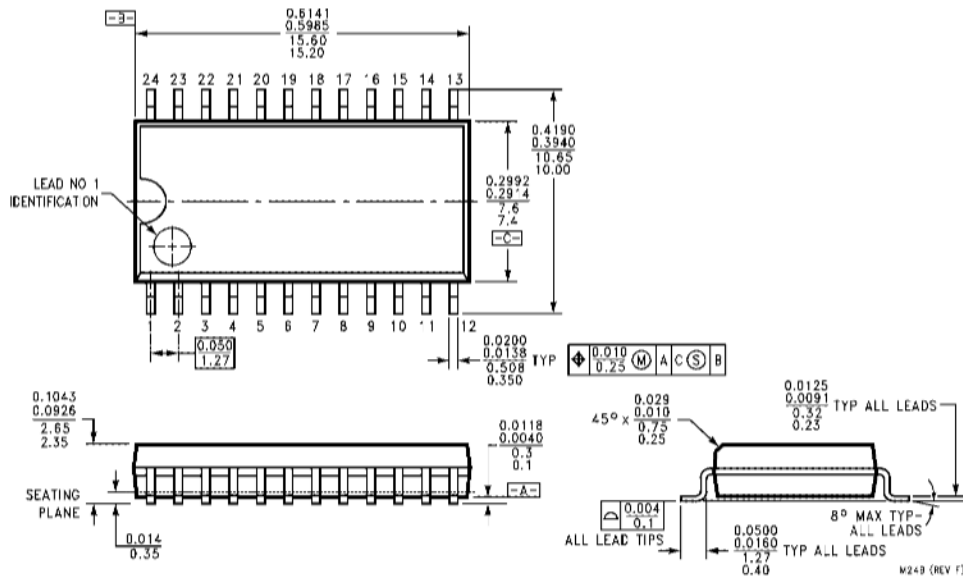

24-Lead Small Outline Integrated Circuit (SOIC), JEDEC MS-013, 0.300 Wide Package Number M24B

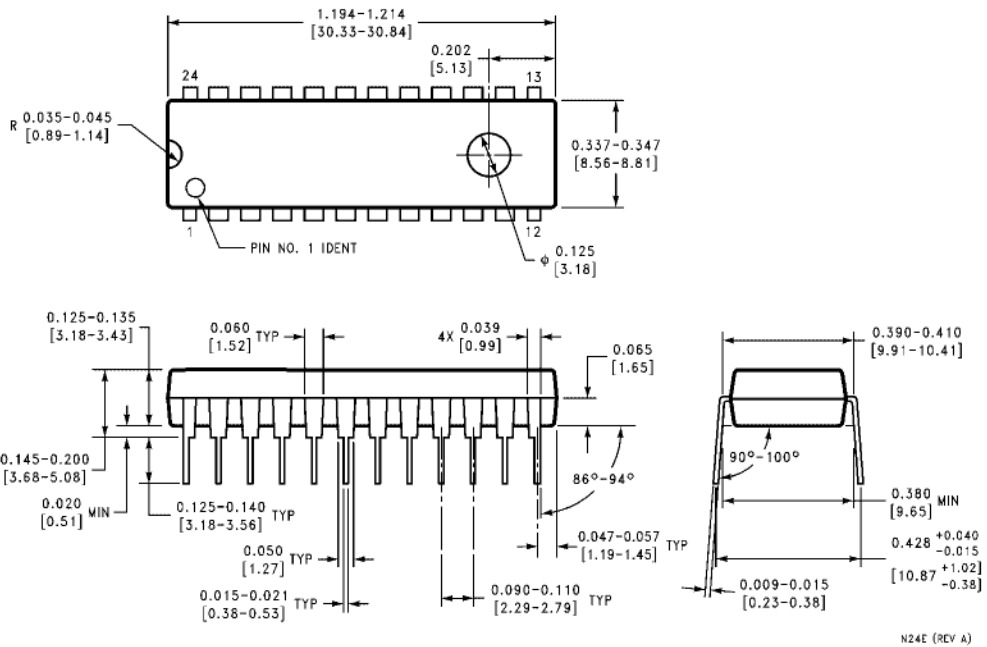

24-Lead Plastic Dual-In-Line Package (PDIP), JEDEC MS-010, 0.400 Wide Package Number N24E

Physical Dimensions inches (millimeters) unless otherwise noted (Continued)

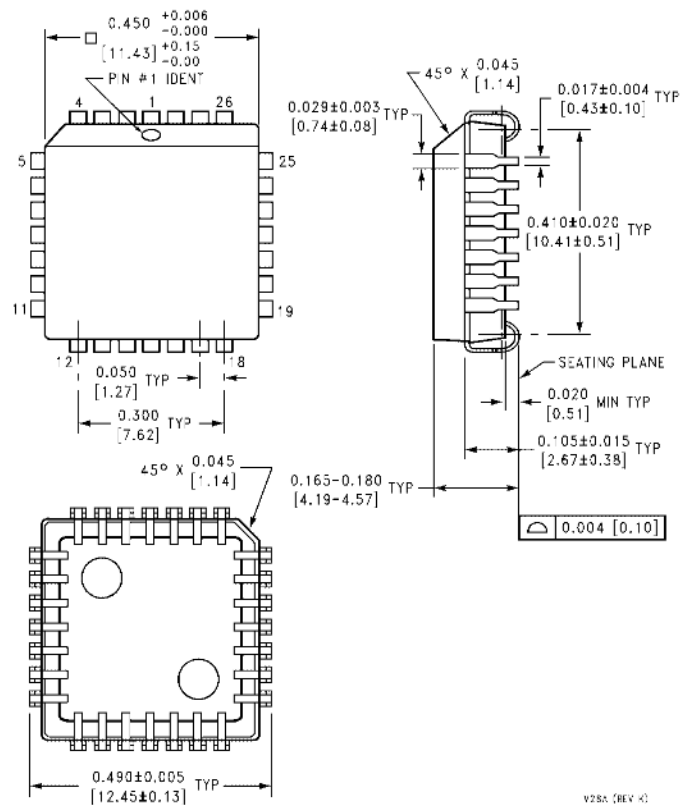

**28-Lead Plastic Lead Chip Carrier (PLCC), JEDEC MO-047, 0.450 Square
Package Number V28A**

Fairchild does not assume any responsibility for use of any circuitry described, no circuit patent licenses are implied and Fairchild reserves the right at any time without notice to change said circuitry and specifications.

LIFE SUPPORT POLICY

FAIRCHILD'S PRODUCTS ARE NOT AUTHORIZED FOR USE AS CRITICAL COMPONENTS IN LIFE SUPPORT DEVICES OR SYSTEMS WITHOUT THE EXPRESS WRITTEN APPROVAL OF THE PRESIDENT OF FAIRCHILD SEMICONDUCTOR CORPORATION. As used herein:

1. Life support devices or systems are devices or systems which, (a) are intended for surgical implant into the body, or (b) support or sustain life, and (c) whose failure to perform when properly used in accordance with instructions for use provided in the labeling, can be reasonably expected to result in a significant injury to the user.
2. A critical component in any component of a life support device or system whose failure to perform can be reasonably expected to cause the failure of the life support device or system, or to affect its safety or effectiveness.

www.fairchildsemi.com